

North Dakota Higher Education Challenge Fund Rules of Operation & Procedures



A matching grant fund for the advancement of higher education academics.

Introduction

The 63rd legislative assembly initiated a program to enhance North Dakota University System institutions through a matching grant fund. The North Dakota Higher Education Challenge Fund is intended to ignite a philanthropic spirit to support North Dakota colleges and universities. The State Board of Higher Education shall award one dollar in matching grants for every two dollars of non-state, non-federal dollars raised by the institutional foundations of North Dakota public colleges and universities for projects dedicated to the advancement of academics. Distributions of grant awards will be made based upon the review and approval of the legislatively prescribed grant review committee.

The grant review committee consists of the Governor, or the Governor's designee, who serves as the chairman of the committee, two members of the House of Representatives Appropriations Committee, two members of the Senate Appropriations Committee, two members appointed by the Governor, and two members appointed by the State Board of Higher Education. A list of the current committee members can be found on the North Dakota University System website under Information Topics or via the link <https://ndus.edu/nd-higher-education-challenge-fund/>.

Grant review committee meetings will be held as needed, on an approximate quarterly basis, and are subject to applicable North Dakota open meetings and open records laws.

Grant review committee meetings will be convened at the call of the chair and applications will be heard in alphabetic order by institution. An oral presentation to the grant review committee shall be given by the institution's President, or a designee of the institution's President. If the latter, this designation must be expressed in writing and signed by the institution's President expressing his/her full knowledge of the application. Along with the President or the President's designee, an institution can invite any other individual to participate in the presentation of the project to the committee. The grant review committee may make recommendations for reapplication regarding the scope or qualifying components eligible for funding of the project. The State Board of Higher Education shall distribute the funds according to the grant review committee's decisions.

Grant & Project Eligibility

To qualify for a matching grant, an institution's application must be approved by the grant review committee and meet the minimum match threshold: at least \$50,000 for the University of North Dakota and North Dakota State University and at least \$25,000 for the other North Dakota University System institutions and the NDSU Agriculture, Research, and Extension. Eligible match contributions can be from individuals, families, corporations, nonprofits, or dedicated campaigns organized by the respective institutional foundation. In kind donations are not eligible for match contributions. In accordance with N.D.C.C. §15-10-50, if the State Board of Higher Education provides grant funds to an institution, on the basis of a monetary pledge, and if the amount forthcoming is less than the amount pledged, the institutional foundation is liable to the institution for any shortfall. Pledges should not exceed seven years.

Private funds that are designated to be matched by the state may not be leveraged again by public funds. The North Dakota University System Foundation is not eligible for a grant.

Endowed Activity

Donations for an endowed activity are eligible for state matching funds. Donations received by the foundation, but not available for use until the death of the donor, are eligible for state match. State funds may be distributed to the foundation upon receipt of the donation. State funds may be used to fund the endowed activity in advance of the private donor's death.

In the event the donor revokes the donation, the institutional foundation is liable for the shortfall.

Funding Amounts & Timelines

Each biennium funds shall be awarded based on N.D.C.C. § 15-10-48 through 15-10-53. If allocated funding has not been awarded by January 1 of the second year of the biennium, the unused funds will be made available to the respective institutions as outlined later in this document. If the remaining dollars are insufficient to provide a matching grant in the amount of one dollar for every two dollars raised by the institutional foundation, the Grant Review committee shall award a lesser amount.

The State Board of Higher Education will retain up to one-quarter of one percent of any grant awarded to assist with administrative expenses. This amount will be deducted from each grant as paid.

Application & Review Process

Scope Application

For all non-scholarship projects, the institution must present the project idea or campaign to the grant review committee for scope approval. This is necessary so that fundraising efforts have confidence that the final application will be approved by the committee. Funds will not be obligated at this point in the process. The application must include how the institution will benefit academically from the project and demonstrate community and student support. Project scope approval can be requested at any point during the biennium. Scope approval applications must be submitted by the respective institution's Office of the President to the North Dakota University System office using State Form Number 60559.

Scholarship applications that meet the statutory rules in N.D.C.C. § 15-10-53 do not require scope approval.

Funding Application

Applications for matching dollars must be submitted by the respective institution's Office of the President to the North Dakota University System office, using State Form Number 60473, and be signed by all required parties. Applications can be submitted at any time to the North Dakota University System office. The application must include how the institution will benefit academically from the project, demonstrate community and student support, and provide documentation of cash or monetary pledges received after July 1 of the first year of the biennium. Requests for state awards must be made to the nearest whole dollar.

Qualifying applications for matching dollars that are exclusively dedicated to the advancement of enhanced academics include investments in research, scholarships, technology, endowed chairs, and investments in educational infrastructure. Examples of applications that are not exclusively dedicated to the advancement of academics include scholarships intended solely for the benefit of athletics, campus facility repair projects, and new capital construction projects. Additionally, aesthetic landscaping costs are not an eligible expense for grant match.

Educational infrastructure is defined as all resources necessary to develop and deliver educational programming, and support effective teaching and learning, in turn facilitating successful students and instructors; **excluding capital construction or structural renovation projects**. Examples of Educational Infrastructure may include, but are not limited to, the items listed below in Table 1.

Table 1:

Description	Type
IT equipment upgrades & installation – switches, routers, wireless access points, wiring	Technology
Electrical wiring to support IT and instructional equipment	Technology
Specialized software, upgrades, installation – delivery of distance ed., other	Technology
Update library resources – create digital collection	Other
Update library or other learning space furniture, fixtures or equipment	Other
Science lab equipment	Equipment
Robotic equipment for STEM learning activities	Equipment
Sound or video equipment	Equipment
Small equipment for student checkout/use – laptops, desktops, thin clients, digital cameras, tablets, iPads, scanners, microphones, other	Equipment
Portable student collaboration stations/digital media labs	Equipment
Smartboards	Equipment
Simulators – nursing/other	Equipment
Books, reference materials or other media and subscriptions to full-text databases and online streaming video	Other
Curriculum research and development for new or expanding programs	Other

In accordance with N.D.C.C. §15-10-48.2, only Awards approved to the NDSU Agriculture, Research, and Extension may be used for endowments, academic scholarships, operations, facility repair projects, and new capital construction projects.

Pooled Funding Application Process & Determination

If designated funds have not been awarded to campuses by January 1 of the second year of the biennium the remaining funds are combined into two separate pools which institutions can access. This funding will be defined as “pooled funding.” See N.D.C.C. §15-10-48(2) and N.D.C.C. §15-10-49(2) identifying the established pools.

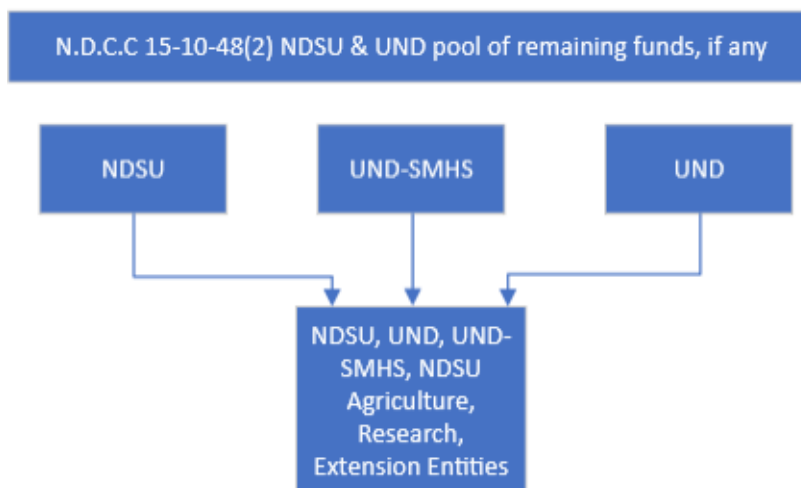

N.D.C.C 15-10-49(2)(c) requires first priority to institutions with the same funding allocation amounts

If funds remain after prioritization of institutions with same funding allocation amounts, then the remaining institutions with requests may be awarded the additional funds

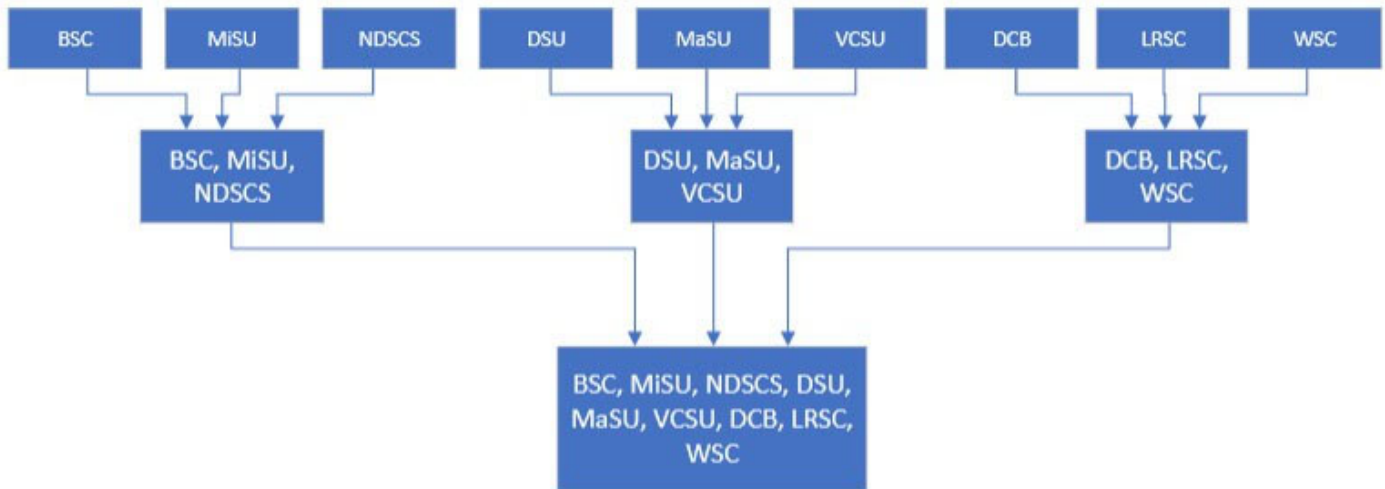

Applications for pooled dollars will be considered in quarterly funding rounds, in the chronological order in which they are received, and until all funding is depleted. Applications must be submitted by the respective institution's Office of the President to the North Dakota University System office, using State Form Number 60473, and be signed by all required parties. The first application round deadline will be in January of the second year of the biennium.

Application information must include a description of how the institution will benefit academically from the project, demonstrate community and student support, and provide documentation of cash or monetary pledges received after July 1 of the first year of the biennium.

For each biennium, and dependent upon the unique circumstances existing at the time, the granting committee can determine, by a majority vote, the manner in which pooled funding will be awarded. If there is not a majority vote for an alternate method of awarding the pooled funds, the committee will utilize a pro-rata method.

Fund Distribution & Reporting

When the application(s) has been approved by the grant review committee, a memo will be sent from the chair to the Commissioner of the North Dakota University System authorizing the distribution of funds. 100% of the state approved funds less the required administrative fee will be distributed to the institution's Office of the President unless the grant review committee or the institution requests an alternate distribution schedule. A memo of understanding (MOU) between the institution and the institution's foundation must be on file with the North Dakota University System office prior to any distributions. Funds will be distributed from the general fund.

Once the grant awards have been approved, modifications may be made to the project's scope, total financial investment, etc. with approval from the grant review committee. Each institution must submit semi-annual reports of the collected and distributed funds as of the reporting date to the North Dakota University System office, utilizing State Form Number 60859, and these reports should also be forwarded to the grant review committee. The purpose of these reports is to provide information for the compilation of periodic status updates and accomplishments to the Governor's Office, Interim Committee on Higher Education legislative committee, and State Board of Higher Education. The reports must include a financial status of the project to date as it relates to the Challenge Grant Fund program.

All funds will be subject to the annual North Dakota University System financial audit as well as the Bi-annual North Dakota University System office operational audit conducted by the State Auditor's Office. The results from these audits will be presented to the grant review committee. All funds are subject to state procurement and open records laws.

Rules of Operation & Procedures Document

This document serves as the rules of operations and procedures for the Higher Education Challenge Fund. It has been reviewed and approved by the grant review committee and forwarded to the State Board of Higher Education and legislative management. Any changes to the rules and procedures will require a majority vote of the grant review committee.

Origination: July 9, 2013
Revised and Approved: November 18, 2015
Revised and Approved: August 15, 2017
Revised and Approved: January 24, 2019
Revised and Approved: June 6, 2019
Revised and Approved: October 4, 2023
Revised and Approved: December 4, 2023
Revised and Approved: March 20, 2024
Revised and Approved: September 23, 2025
Revised and Approved: December 15, 2025